



LLENADO DE
VEHÍCULOS



SISTEMA DE GESTIÓN
DE COMBUSTIBLE



KITS



BOMBAS



MEDIDORES



MEDIDORES
PARA PISTOLA

SUZZARABLUE DRUM

CARACTERÍSTICAS

- DISEÑADO PARA BIDONES DE 200 L
- FÁCIL DE INSTALAR
- BOMBA SUZZARABLUE

PIUSI SUZZARABLUE DRUM PIUSI es la solución para todas las aplicaciones de AdBlue® en bidones. Su soporte regulable facilita la instalación en cualquier tipo de bidón.

RENDIMIENTO

HASTA

32 L/MIN

DE CAUDAL

CA
TENSIÓN

DE ALIMENTACIÓN

20 MIN

DE CICLO DE SERVICIO



SUZZARABLUE DRUM

PACKAGING

CÓDIGO	PESO		PACKAGING		
	KG	LBS	MM	PULGADAS	UDS./CAJA
FOO20135E	16	35,3	470X370X265	18,3X14,6X10,4	1
FOO201D5C	16	35,3	470X370X265	18,3X14,6X10,4	1
FOO201E5C	16	35,3	470X370X265	18,3X14,6X10,4	1



PISTOLAS



FILTRACIÓN

MONITOREO
DE DEPÓSITOENROLLADORES
DE MANGUERA

ACCESORIOS

MATERIAL
PROMOCIONAL

INDEX

CONEXIÓN
DE AIREANTI-
CONGELANTE

AdBlue®



BIODIÉSEL



GASÓLEO



ALIMENTOS



GASOLINA



GRASA



QUEROSENO



ACEITE



AGUA

LIMPIA-PARA-
BRISAS

GRÁFICOS

SUZZARABLUÉ AC

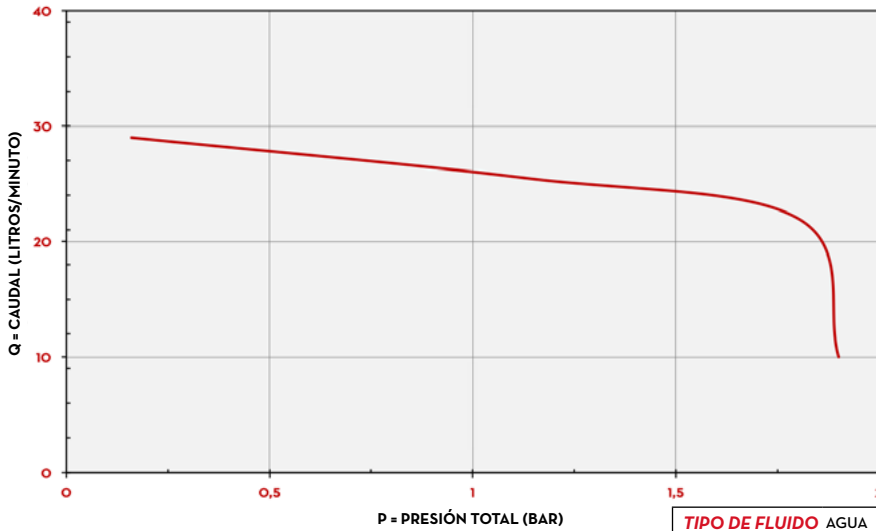

TIPO DE FLUIDO AGUA

TEMPERATURA 20°C

DIMENSIONES

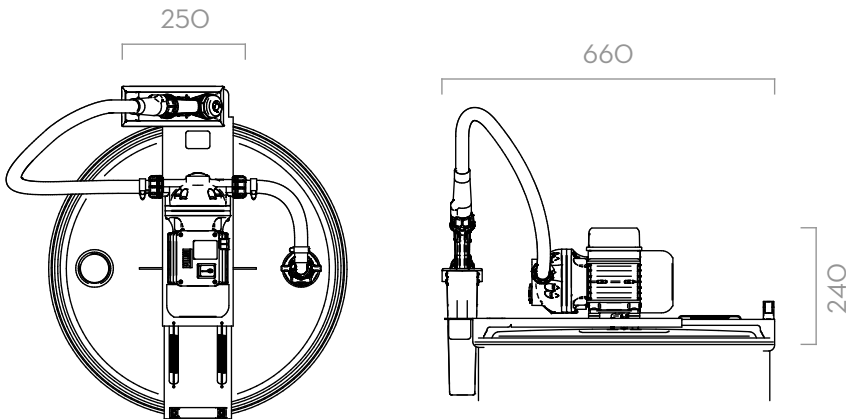

Las dimensiones se expresan en milímetros

CONTENIDO DE LA CAJA

- UNIDAD SUZZARABLUÉ DRUM
- PISTOLA
- MEDIDOR SB325_X / SB325_X
- (BAJO PEDIDO)
- CONECTOR AF2
- TUBO DE SUCCIÓN
- MANGUERA DE SUMINISTRO
- MANUAL DE INSTRUCCIONES

DETALLES

BOMBA SUZZARABLUÉ
PUMP AC

CONECTOR AF2



TUBO DE SUCCIÓN

COMPONENTES

- BOMBA:
SUZZARABLUÉ PUMP AC
- PISTOLA:
SB325_X METER
SB325_X
SUZZARABLUÉ MANUAL NOZZLE

FICHA TÉCNICA

CÓDIGO	DESCRIPCIÓN	TIPO DE FLUIDO	CAUDAL		TENSIÓN			MEDIDOR	PISTOLA	SUCCIÓN	MANGUERA		ON/OFF SWITCH
			L/MIN	GPM	CA V./HZ CC VOLT	POTENCIA WATT	AMP. MAX.				LONGITUD	Ø	
FOO20135E	SUZZARABLUÉ DRUM 230V/50HZ		32	8,5	230/50	400	1,95	NO	MAN.	AF2	6 M	3/4"	SI
FOO201D5C	SUZZARABLUÉ DRUM 230V/50HZ - SB325_X		32	8,5	230/50	400	1,95	NO	SB325	AF2	6 M	3/4"	SI
FOO201E5C	SUZZARABLUÉ DRUM 230V/50HZ - SB325_X MET		32	8,5	230/50	400	1,95	SB325_X	SB325_X	AF2	6 M	3/4"	SI

PARA TAMBOR